

# Operation & Maintenance Manual

3900 Single Tank Time Clock & Metered Systems





---

---

# **Operation & Maintenance Manual**

**3900 Single Tank Time Clock & Metered Systems**

---

---



---

# Table of Contents

## 1 INTRODUCTION

## 2 PRINCIPLES of ION EXCHANGE

- 2.1 Ion Exchange Softening Process
- 2.2 Quality of Effluent
- 2.3 Capacity of Ion Exchange
- 2.4 Regeneration Steps

## 3 INSTALLATION, LOADING & START-UP PROCEDURES

- 3.1 Installation of Equipment
- 3.2 Loading of Gravel & Resin
- 3.3 Start-Up Procedures

## 4 OPERATING & REGENERATION PROCEDURES

- 4.1 Normal System Operations
- 4.2 Multi-Port Valve Operation

## 5 OPERATING RESPONSIBILITIES

- 5.1 Operator procedures
- 5.2 Salt Specifications

## 6 TROUBLE SHOOTING

- 6.1 General
- 6.2 Reduced Capacity or Poor Effluent Quality
- 6.3 Increase Pressure Loss or Decrease in Flow Rate

## 7 SOFTENER SYSTEM DRAWINGS AND SPECIFICATIONS

- 7.1 Typical Single Unit Installation
- 7.2 Specifications
- 7.3 Brine Float Setting
- 7.4 Commercial/Industrial Brine Tanks

## 8 3900 CONTROL MANUAL

## 9 SOFTENER ADDENDUM

- 9.1 Sample – Water Softening Log
-



---

# Foreword

The operating instructions contained herein are intended to serve as a guide for the operation of the water softener equipment.

Since it is impossible to cover all operating contingencies and emergencies in a normal operating manual, the operator should read the manual and become familiar with its contents. They should also review the flow diagrams and vendor literature. This also should include all physical details, and full knowledge of the location and function of the equipment.

The use of an operating logbook is recommended in order to provide a proper record of performance. In the event of operational problems, such a record will prove invaluable when “trouble shooting” the system. This log should include all pertinent flow rates, temperatures and water characteristics. Equipment requiring maintenance or repair should be noted so that it can be scheduled for service or repair.

Frequently, water softener equipment like other processes, develop their own distinct characteristics. Design criteria outlined in this manual is based on many years of experience. However, they do not preclude modifications due to “personality” of the system. Operators should guide themselves accordingly and make any minor adjustments necessary for proper operation of the system.

---

---

---

# Section 1: Introduction

Long term, successful operation of any softening system depends upon the care and attention it receives. Ordinarily, water treatment systems will provide uniform performance after the initial start-up period. Total gallons between regenerations and treated water purity usually do not vary appreciably over the life of the resin as long as the incoming water does not change.

This manual is intended to be a practical reference guide for operators. In view of the fact that system performance can change very dramatically throughout the year, a discussion of "ion exchange" theory is included in addition to basic information relative to equipment operation and regeneration procedures. Thorough understanding of the simple chemical reactions will help to determine if some equipment malfunction has occurred, or if the system is simply responding to changing water conditions. For this reason, the operator and supervising personnel should review Section 2, which defines terminology and simple chemistry associated with this system.

Ion exchange (softening process) is a reversible reaction. Ion exchange softening resins have only a limited capacity for removing hardness (calcium & magnesium). If the volume of water through the resin bed exceeds its capacity, hardness leakage will be detected in the effluent water. Therefore, service runs must be terminated before hardness leakage occurs. When the service run is completed, the resin is treated with sodium chloride (NaCl) to displace the hardness and restore its capacity. This process is termed "regeneration".

How completely softening can be accomplished depends upon several factors. The primary influences are the incoming water, type of resin, and amount of salt. Equally important, secondary influences are the concentrations and flow rates at which NaCl is introduced.

---

---



---

---

# Section 2: Principles Of Ion Exchange

## 2.1 Ion Exchange Softening Process

In order to understand the softening process of ion exchange, it is first necessary to understand the meaning of the terms which are used in the explanation. Hard Water, Cation Exchanger, and Brine are defined below and used to show how the ion exchange process works.

**Hard Water** – All natural water contains dissolved impurities, but in widely varying amounts. There is always a balance of cations (+) and anions(-), but in the softening process anions have no effect. Water will be hard if it contains large amounts of calcium ( $\text{Ca}^{++}$ ) and/or magnesium ( $\text{Mg}^{++}$ ) ions.

**Brine** – Salt which has dissolved in water. Completed brine (100%) saturation contains as much salt as possible in water solution (26% to 27%). Salt – Sodium chloride ( $\text{NaCl}$ ), when dissolved in water splits up (ionizes) into sodium ( $\text{Na}^{+}$ ) ions and chloride ( $\text{Cl}^{-}$ ) ions.

**Saturated Brine** – Contains a large amount of  $\text{Na}^{+}$  and  $\text{Cl}^{-}$  ions (concentration is over 200,000 ppm). When used to regenerate a cation exchanger, only the sodium ( $\text{Na}^{+}$ ) ions are used. The chloride ( $\text{Cl}^{-}$ ) ions are washed to drain.

**Cation Exchanger** – A high-capacity bead form polystyrene sulfonate cation resin. These beads have negative (-) electric charge, which attracts and holds the cations, which are positively (+) charged (works like a magnet).

**Softening Process** – When the bead reaches the exchange capacity of  $\text{Ca}^{++}$  or  $\text{Mg}^{++}$  hardness break through the resin bed will increase. The increase in effluent hardness will indicate that the effective capacity of the cation resin has been reached. The cation exchanger must be regenerated to restore it to its original capacity.

**Regeneration** – Brine is used to regenerate the cation exchanger to its original capacity. Sodium ( $\text{Na}$ ) ions attach to the resin beads forcing the calcium and magnesium ions to release from the resin beads. Once the exchange has taken place the sodium ions are rinsed to drain. The softener is now ready to remove hardness from the water.

---

---

---

---

## 2.2 *Quality Of Effluent*

If the hard water contains less than 500 ppm (about 30 grains) of calcium, magnesium and sodium salts, all expressed as  $\text{CaCO}_3$ , it will be found that the effluent from a softener will contain an average of not more than 2 ppm actual total hardness (zero hardness by the soap test). However, as the total cation concentration in the hard water increases above 500 ppm, the average hardness in the effluent will also increase proportionately

The reason for this is that when the sodium salt - those present in the raw water plus those formed by the exchange reactions - are present in high enough concentrations, they cause a "back-regeneration" effect at the same time as the softening process is taking place. This effect prevents as complete a removal of calcium and magnesium as would otherwise be possible.

It is often possible to reduce the average hardness in the effluent below normally expected concentrations, by using a greater amount of salt than usual for regeneration. Normal Softening Cycle - At the start of a normal softening cycle, the hardness in the effluent drops rapidly as the residue of hardness ions left in the bed at the end of the rinse are forced out. The effluent hardness reaches a certain minimum value and remains at approximately this concentration for the major part of the softening run.

## 2.3 *Capacity Of Ion Exchanger*

The capacity for the removal of calcium and magnesium depends mainly upon the type of ion exchanger which is used. It is further influenced by the amounts of hardness and sodium ions in the raw water, and by the amount of salt used for regeneration.

**Raw Water** - The effect of the amounts of hardness and sodium ions in the raw water, is expressed in terms of compensated hardness. The hardness of the raw water is considered to be greater than it actually is for capacity determinations, whenever: (a) the total hardness is greater than 400 ppm (as  $\text{CaCO}_3$ ), or (b) the sodium salts are over 100 ppm as ( $\text{CaCO}_3$ ). This "greater-than-actual" hardness is referred to as compensated hardness.

**Salt Dosage** - The capacity, which will be obtained from a cation exchanger, is also determined by the amount of salt used during regeneration. The grains of hardness, which can be removed by each cubic foot of ion exchange, resin increases as more salt is used for regeneration.

At the same time, the efficiency of salt usage decreases with the higher regenerant dosages. That is, a greater number of grains of hardness are removed for each pound of salt used at the lower salt dosages, (and consequently, at the lower capacities). Thus, greater economy may be obtained at the expense of the number of gallons of water softened between regenerations.

---

---

---

---

**Calculation Of Capacity** - To determine the capacity of any cation exchanger, follow the procedure outlined below:

From the analysis of the raw water, determine the actual total hardness as the sum of the calcium and magnesium concentrations expressed as CaCO<sub>3</sub>. If necessary, calculate the compensated hardness in accordance with the formula given above.

Express parts per million (ppm) of total hardness as grains per gallon by means of the following conversion formula:

$$\text{PPM} / 17.1 = \text{grains per gallon (gpg)}$$

## **2.4 Regeneration Steps**

Regeneration is a process by which ions are stripped from the exhausted resin bed and its ion removal ability is restored. All exchangers, ranging from a simple water softener to a complex mixed bed deionizer go through four basic regeneration steps. There may be variations in flow rates; types of regenerating chemicals and regenerant concentrations but these general steps are as follows:

**Backwash** - Water flow is reversed so that it passes upward through the resin bed. Flow rates are sufficiently high to expand (fluidize) and to agitate the bed without washing large resin particles out of the tank. This action relieves any compaction that may have occurred during the service run. In addition, very fine resin fragments that can form during normal service are washed to drain. Proper backwash is essential to good exchanger performance. A compacted bed can develop high-pressure losses during service, which, in turn, can lead to flow channeling problems.

**Brine In** - A brine solution is passed slowly through the resin, displacing the exchanged ions and discharging them to drain. Proper control of flow rate and brine concentration is important to insure high regeneration efficiency. The amount of salt that is used depends upon the allowable hardness leakage for any given water supply and the desired resin operating capacity.

**Displacement Rinse (Slow Rinse)** - After all of the brine has been introduced into the resin bed, water continues to flow at approximately the same low flow rate. This slowly displaces the salt from the free space above the bed and from the void volume between resin particles, insuring that it is utilized to maximum efficiency.

**Final Rinse** - The final step in regenerating is important in that it will displace any salt left in the exchanger vessel prior to returning to service.

---

---

---

---

# Section 3: Installation, Loading & Start Up Procedures

## 3.1 *Installation of Equipment*

1. Before beginning installation, review the following instructions to familiarize yourself with the general placement of the equipment.
  2. The operating pressure is between 30 to 100 psi. If pressure is higher than 100 psi, then a pressure regulator must be installed.
  3. The operating temperature is between 35 to 100 degrees F.
  4. Locate the equipment in the specified location. When setting the equipment, install on level concrete pad if possible. Level equipment as required.
  5. Equipment should be located near a floor drain. The floor drain should be adequate in size to handle the softener backwash flow rate.
  6. Interconnecting piping and shut off valves of equipment should be installed per local plumbing codes by a certified plumber.
  7. Unions to be installed in the drain line for cleaning of the backwash flow control. Do NOT reduce the drain line pipe size, or install a manual shut off valve. Provide an air gap in the drain line in accordance with local plumbing codes.
  8. Before installing any flow meters, read the instruction manual on proper installation of the sensor. Many flow meters must be installed in a certain way to operate properly.
  9. Once installed close all manual shut off valves.
  10. Brine tank should be located near the softeners, installed on a smooth flat surface. If not the brine tank should be placed on a smooth piece of exterior plywood and level.
  11. Once the brine tank has been set in place, remove the lid and check that the brine well is in a vertical position. If the brine tank is equipped with a brine valve/float assembly, remove and check to make sure the brine float setting is correct (See Section 7 – Brine Float Setting). The float will have a certain setting depending on the amount of salt used per regeneration. If incorrect adjust float to proper setting.
  12. Place brine valve into brine well and set all the way to the bottom of the brine tank.
  13. Fill brine tank with approximately 13-19 inches of water. The water level should be approximately half to the height of float setting.
- 
-

---

## 3.2 Loading Gravel & Resin

1. Before loading the gravel, check the lower distributor for possible damage from shipping. Making sure all laterals are in proper location. Do NOT proceed with loading if any damage is evident.
2. Once the distributor is checked out ok, plug the end of the distributor tube with a PVC cap/plug, clean rag or tape to keep the gravel and resin out of the center of the riser.
3. Fill the tank approximately 1/4 -1/3 full of water. The water will act as a buffer when loading the gravel and prevent any damage to the lower distributor.
4. Determine the amount of gravel and resin required for each tank. **When coarse, medium and fine gravels are specified, add in that order.** Slowly pour the gravel into the tank. Try to keep it as level as possible.

***(Not all systems have multiple sizes of gravel)***

5. Once the gravel has been loaded. Slowly pour the determined amount of resin into the tank. Try to keep it as level as possible.
6. Flush the tank opening with water to clean resin beads from the top of the tank. Then, remove the cap, plug, rag or tape from the distributor pipe. Apply a light coat of approved lubricating silicone to the top edge of the pipe. **(DO NOT USE PETROLIUM LUBRICANTS, ie. Vaseline)**
7. Finish filling the tank with water, up to the top. This will eliminate air space and prevent excessive air – head pressure when the water conditioner is pressurized.
8. Once completed, lubricate the o-ring and carefully install control valve, then secure the top flange.
9. Keep power off until final checkout procedure is completed.

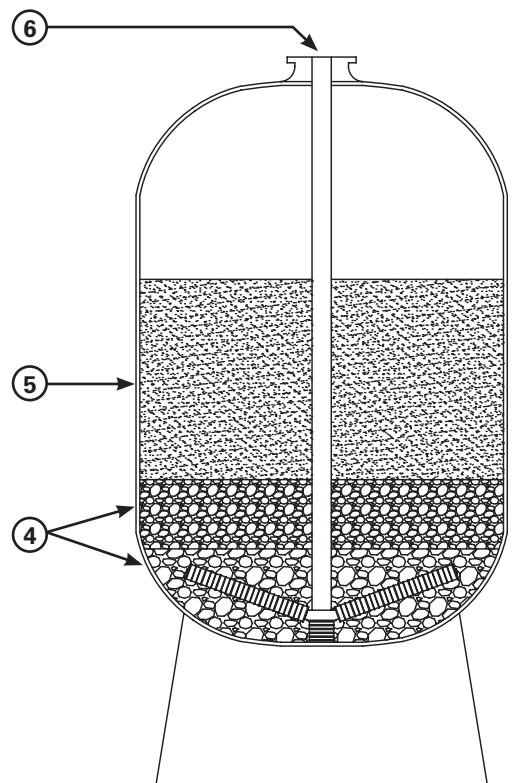
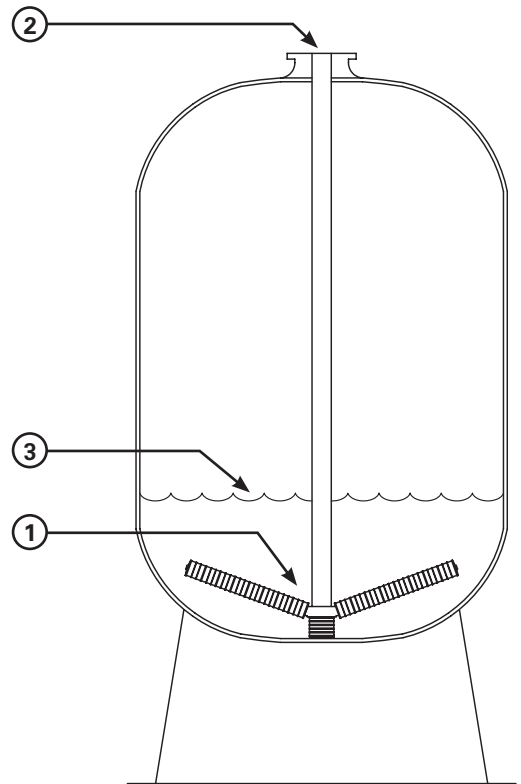

---

---

### 3.3 *Start-Up Procedures*

1. Once the piping and installation completed, and with the mineral in the tank, proceed with the following.
2. Open the manual by-pass valve. The manual inlet and outlet valves are to remain closed.
3. Plug electrical power of the main controller to a wall outlet (120v)
4. The main controller is a Fleck Model 3900. The control is either configured for "Meter Initiated Regeneration" or "Timed Regeneration". The controller now is ready to be programmed.

#### **How to calculate a softeners capacity and setting for a "Meter Initiated" system.**

Calculate the "Gallon Capacity Of The System". This is a function of the system size and the hardness of the water.

For example, assume the system capacity is 300,000 Grains and the hardness of the water is 30 Grains Per Gallon. The "Gallon Capacity Of The System" is 10,000 Gallons (300,000 divided by 30).

Additionally, assume that the facility uses 2,500 gallons of water per day. The program wheel on the control valve would be set at 7,500 gallons.

For more details on setting the timer on a "Meter Initiated" System, see page 20 of Section 8 titled "Model 3210 Econominder".

***Note: The Fleck "Standard Range" Meter has can meter up to 21,250 gallons. In some cases, it may be necessary to install an "Extended Range" Meter which can meter up to 106,250 Gallons.***

***Note: The presence of iron and other contaminants in the water may affect the above calculation.***

#### **How to calculate a softeners capacity and setting for a "Timer Initiated" system.**

Calculate the "Gallon Capacity Of The System". This is a function of the system size and the hardness of the water.

For example, assume the system capacity is 300,000 Grains and the hardness of the water is 30 Grains Per Gallon. The "Gallon Capacity Of The System" is 10,000 Gallons (300,000 divided by 30).

Additionally, assume that the facility uses 2,500 gallons of water per day.

The timer on the control valve would have to be set to initiate regeneration every four days (10,000 divided by 2,500 = 4).

For more details on setting the timer on a "Timer Initiated" System, see Section 8 – 3900 Control Valve – 3200 Settings.

***Note: The presence of iron and other contaminants in the water may affect the above calculation.***

---

---

- 
- 
5. Once the programming is completed, manually set the valve unit into backwash. Slowly open the manual inlet valve. **DO NOT OPEN INLET VALVE COMPLETELY.** (Full flow of water could cause loss of resin) Water will enter in the bottom of the mineral tank, causing any air to expel from top to the drain. Continue to slowly fill until all the air has expelled from the tank and only water flows to drain.
  6. When only water flows to drain, open manual inlet valve completely and continue backwashing until water is clear from any color.
  7. Manually set the unit through regeneration one step at a time. When doing this make sure the piston completely comes to a stop before proceeding to the next step.
  8. Fill brine tank with proper amount and type of salt recommended.
  9. Close the manual by-pass valve and open manual outlet valves. The system is ready for service.

## **Section 4: Operating & Regeneration Procedures**

### ***4.1 Normal System Operation***

The system is designed for fully automatic operation. Service runs will automatically terminate when an exhaustion end-point is reached.

Although it should not be absolutely necessary to observe every regeneration, Operators should periodically witness a complete cycle to make sure that critical flow rates and steps have not gotten out of adjustment.

#### Daily

- Date and Time
- Meter Reading
- Outlet Hardness
- Inlet Hardness
- Inlet and outlet pressure gauge readings; calculated pressure drop
- Record Salt Usage

#### Miscellaneous

All of this information can be invaluable in detecting if something is going wrong, or when trouble shooting. High-pressure drop during the run can be symptomatic of buildup of suspended solids on the bed or excess breakage of resin beads. Short runs or higher than normal effluent hardness could be caused by resin fouling. This could be caused by malfunction during regeneration or even a contaminated batch of salt.

---

---

---

---

## **4.2 Multi-Port Valve Operation**

### **(See Section 8 – Fleck 3900 Control Manual)**

Multi-port valve consist of Fleck 3900 multi-port double piston operated valve. The valve operates with upper and lower piston that moves on a seals and spacer assembly. The upper piston is for regeneration and the lower piston is for service. The piston moves to a certain location, which determines the operation position of the unit.

#### SERVICE

During service flow, raw water passes through the valve and downflow through the softener up through the distributor tube to service. Service flow continues until the water meter/counter has signaled an end of run and will automatically switch service flow to the other unit and go into regeneration.

#### REGENERATION

Based on 10 grains/gallon of hardness as  $\text{CaCO}_3$ , approximately 3000 gallons of water per cubic foot of resin in the softener can flow before exhaustion of resin.

#### BACKWASH

Raw water flow is diverted to pass down through the distributor tube and up-flow through the softener. The water expands the bed scrubbing the resin beads and washing any entrapped dirt out to drain. Backwash sequence lasts approximately 15 minutes.

#### BRINE AND SLOW RINSE

Raw water is directed through the ejector located at the multi-port valve creating a venturi action in the ejector to draw the required amount of brine into the softener. The brine float air check valve shuts off the brine flow when the preset draw down is reached. Raw water continues to the drain slow rinsing the resin for the remainder of the cycle. Brine and slow rinse sequence generally lasts 60 minutes.

#### FAST RINSE

Raw water passes through the multi-port valve down flow through the softener and out to drain. This sequence removes all remaining brine from the resin and lasts 10 minutes. When the regeneration cycle is completed and the softener goes back into service, raw water will backflow through the ejector refilling the brine tank to its normal level. The brine valve float will control water makeup level.

---

---



---

---

# Section 5: Operator Responsibilities

## 5.1 Operator Maintenance

Long term, reliable system performance depends upon how conscientiously the equipment is operated and maintained. Operator responsibilities should include the following recommended practices:

- 1 Maintain Operating Logs - Operators should maintain close control of the process by monitoring system performance daily. Effluent hardness, service run lengths and pressure drop should be recorded. Since resins are subject to fouling, decrease in product quality or run length could be the result of fouling. In addition to operating data, log notations should include equipment design changes, or modifications in programmed times. This information can be invaluable if trouble shooting is ever required.
- 2 Check Regeneration Flow rates - Check and adjust flows during regeneration on a regular basis.
- 3 Institute, a Program of Preventative Maintenance - Setup a definite schedule for routine maintenance. Typical recommended practices are: annual resin sampling and analysis; and annual inspection, lubrication and/or replacement of diaphragms on all diaphragm valves.

## 5.2 Salt Specification - Use Salt As Specified.

- a. *Type* - Rock salt or evaporated salt
  - b. *Color* - White to grayish white
  - c. *Composition* - Not less than 98% sodium chloride, with a minimum of calcium and magnesium salts; zero phenolphthalein alkalinity (Alkalinity P); no grease, fat, or oil content
  - d. *Fineness* - Softeners using polyethylene brine tanks, with no gravel in the bottom, must use an extra coarse grade of rock salt.
  - e. *Solubility* - The salt should dissolve rapidly without packing, to form a clear solution.
- 
-

---

---

# Section 6: Trouble Shooting

## 6.1 General

The most common system failures are either "poor water quality" or "short service run. If the change in performance occurs suddenly -i.e., within a couple of operating cycles, 9 times out of 10 these problems result from:

- a Insufficient regenerating chemical quantity,
- b Poor control of chemical concentrations and/or flow rates,
- c Over-running (over exhausted) resin beds during a service run
- d Flow channeling because of a plugged or failed internal flow distributor.

If however, the change occurs gradually over a period of weeks or months, the problem is more likely due either to a change in feed water mineral content or from fouling of the resins. Under any circumstance, the importance of maintaining Operating Logs cannot be stressed too strongly. Study of the Log will often reveal any trend that might be developing. In the case of fouling, periodic resin analyses are the only way to identify such problems.

General guidelines that will assist in determining common operating difficulties are given below. Often poor performance results because of one or more contributing factors. The recommended approach is to go systematically through the list to see what symptoms apply and then to take corrective action.

## 6.2 Reduced Capacity Or Poor Effluent Quality

<u>SOURCE OF TROUBLE</u>	<u>POSSIBLE CAUSE</u>	<u>CORRECTIVE ACTION</u>
<b>Change In Chemical Composition Of Raw Water</b>	Higher hardness in raw water	Check hardness by chemical test. If it has changed, compute new capacity and use new meter setting
<b>Softener Being Overrun Consistently</b>	Raw water has more hardness	Check raw water hardness and meter setting. Give unit a "double regeneration
	Meter setting is incorrect	Reset meter per manual
<b>Incorrect Chemical Test Results</b>	Test procedure in error	Follow instructions carefully
	Chemicals for test causing error	Replace weak or contaminated test solutions
<b>Meter Slippage</b>	Worn or damaged meter	Replace or repair as necessary

---

---

<b>Inadequate Regeneration</b>	Using a weak (less than 22 Be) brine solution	Recharge at required times Use salt which meets specification
		Use correct amount of dilution water
	Not using enough salt	Check text for specified amount. Use correct saturated brine draw (or pumpage)
<b>Loss Of Ion Resin</b>	Surges during backwash	Install pressure regulator
		Replace lost ion exchanger resin
<b>*Fouling Of Ion Resin</b>	Oxidized iron (Fe) or manganese (Mn) coating resin	If iron & manganese are in oxidized form at source, provide filter to remove. If water supply is clear when first drawn (Fe & Mn are in soluble form) eliminate any air leaks from suction piping. Do NOT feed chlorine or other oxidizing chemicals before softening the water
	Organic matter (slime) coating resin	Provide treatment to destroy organic matter
<b>Damage To Ion Resin</b>	High concentrations of chlorine (or other oxidizing agents) in water.	Add reducing agent (such as Sodium Sulfite) or otherwise remove
<b>Channeling</b> - caused by:		
1. Dirty or packed bed	Backwash rate too low	Adjust controller to correct rate
	Dirty inlet water or backwash water	May require pretreatment
2. Gravel hills, tipped bed or potholes	Careless placement of supporting bed	Inspect and probe bed
	Surges during backwash	Install pressure regulator
	Air in backwash water.	Eliminate air leaks and cause of surges

\*NOTE: It is sometimes possible to restore a fouled bed to its original condition, or very nearly so.

---

---

### ***6.3 Increase Pressure Lose Or Decrease In Flow Rate***

**Dirty Or Packed Bed** - See above for possible causes and corrective actions.

**Restricted Flow** – Obstruction in meter, piping or valves. Inspect and clean as required.

---

---

---

---

# Section 7: Softener System Drawings & Specifications

## 7.1 Typical Single Unit Installation

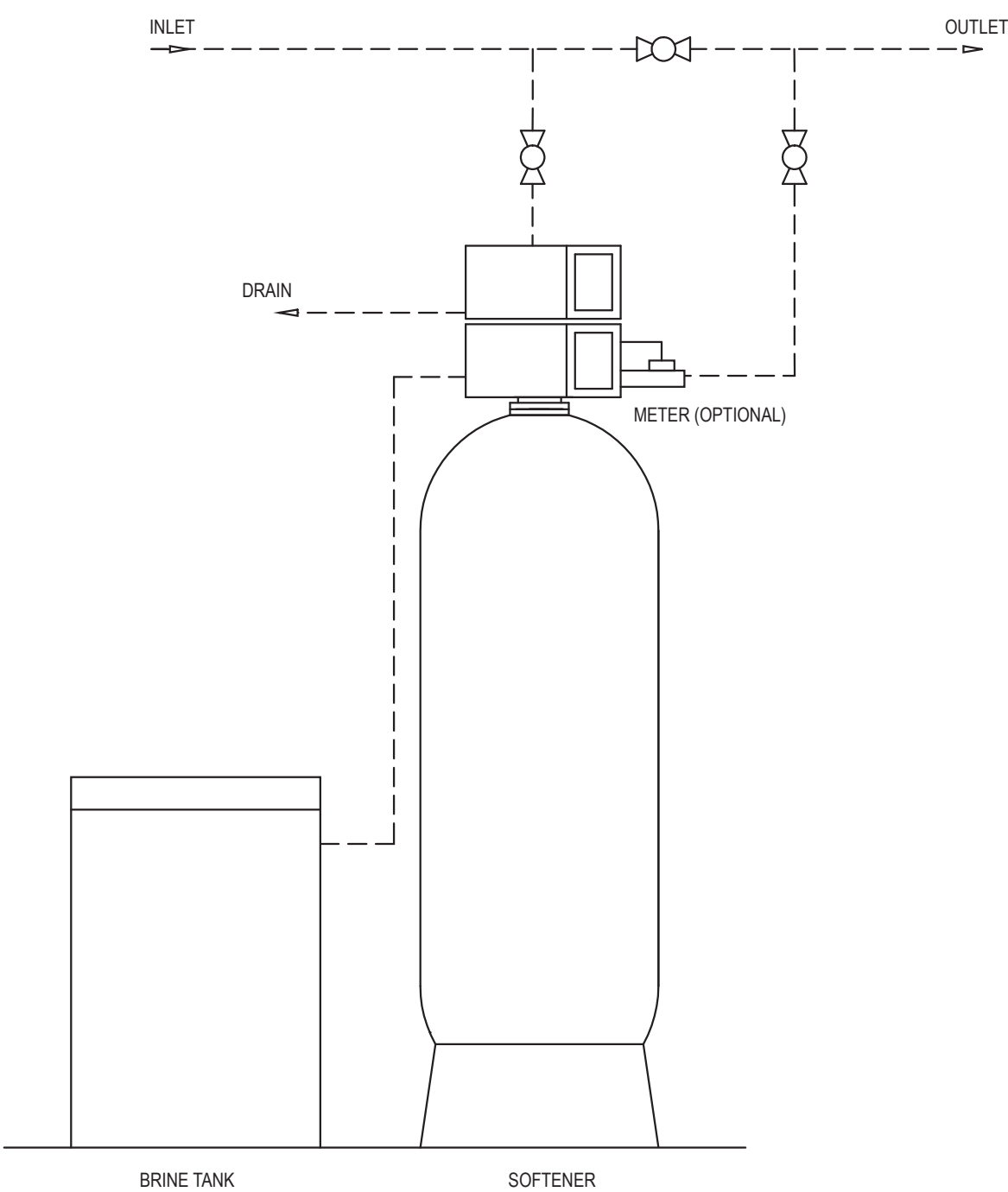

SEE SECTION 8 - 3900 MANUAL - FOR GENERAL ARRANGEMENT PIPING

---

---

## 7.2 Specifications

<b>3900 Specifications</b>					
<b>Model</b>	<b>300,000</b>	<b>450,000</b>	<b>600,000</b>	<b>900,000</b>	<b>1,200,000</b>
Capacity (1)	300,000	450,000	600,000	900,000	1,200,000
Capacity (2)	240,000	360,000	480,000	720,000	960,000
Media Tank Size	24" x 72"	30" x 72"	36" x 72"	42" x 72"	48" x 72"
Resin, Cubic Feet	10	15	20	30	40
Resin, Pounds	500 #	750 #	1000 #	1500 #	2000 #
Gravel Underbed, 1/4" x 1/8"	100 #	100 #	150 #	250 #	300 #
Gravel Underbed, 1/2" x 1/4"	150 #	250 #	350 #	450 #	600 #
Max Service Flow Rate, GPM (3)	170	210	250	270	280
Min Service Flow Rate, GPM	120	155	185	200	205
Backwash Flow Rate, GPM	15	25	35	50	65
Backwash, Minutes	10	10	10	10	10
Backwash, Pins	5	5	5	5	5
Brine Draw and Rinse, Minutes	60	60	60	60	60
Brine Draw and Rinse, Holes	30	30	30	30	30
Rapid Rinse, Minutes	10	10	10	10	10
Rapid Rinse, Pins	5	5	5	5	5
Salt Required (1)	150 #	225 #	300 #	450 #	600 #
Salt Required (2)	90 #	135 #	180 #	270 #	360 #
Refill Time, Minutes (1)	26	16	20	16	14
Refill Time, Holes (1)	13	8	9	9	9
Refill Time, Minutes (2)	16	10	12	10	8
Refill Time, Holes (2)	8	5	6	5	4
Return To Service, Minutes	4	4	4	4	4
Return To Service, Pins	2	2	2	2	2
Brine Line Flow Control, GPM	2	5	5	10	15
Injector Size	# 4	# 5	# 6	# 7	# 8
Injector Color	Green	n/a	n/a	Blue	Yellow

Notes:

(1) - At 15 Pounds Per Cubic Foot yields 30,000 Grains Capacity Per Cubic Foot.

(2) - At 9 Pounds Per Cubic Foot yields 24,000 Grains Capacity Per Cubic Foot.

(3) - At 15 PSI Pressure Drop.

### 3" Meter Range

Standard Range, 3" - 63,750 Gallons

Extended Range, 3" - 318,750 Gallons

## 7.3 Brine Float Settings

Tank Size	Cu. Ft.	Brine Tank	Brine Valve <sub>1</sub>	Salt Deck <sup>2</sup>		Brine valve set at <sup>3</sup>	
				Yes	NO	9lb/cf.	15lb/cf.
30 x 72	15	30 x 48	494	9"		26"	44"
		39 x 48	494	9"	X	38"	—
36 x 72	20	39 x 48	494	9"		14"	25"
		42 x 60	494	9"	X	23"	34"
42 x 72	30	42 x 60	494	12"		18"	39"
		50 x 60	494	12"	X	30"	—
48 x 72	40	42 x 60	494	9"		17"	30"
		50 x 60	494	9"	X	26"	39"
48 x 72	40	42 x 60	494	12"		27"	—
		50 x 60	494	12"	X	39"	—
48 x 72	40	50 x 60	494	12"		16"	29"
		60 x 60	494	12"	X	28"	41"
48 x 72	40	50 x 60	494	12"		29"	—
		60 x 60	494	12"	X	37"	—
48 x 72	40	60 x 60	494	12"		—	26"
		60 x 60	494	12"	X	26"	38"

**Notes:**

- 1 - Brine Valve Clack 494 – 1" connection
- 2 - Salt deck height as noted.
- 3 - Float setting from bottom of brine tank.

# 494 1" Commercial Brine Valve



Order No. H4900

U.S. and Foreign Patents Pending

Built from a revolutionary new design the 494 1" commercial brine valve delivers on today's demand for simplicity and higher brine draw and refill rates. The 494's "top of brine tank" design allows for easy access and serviceability as well as brine draw rates up to 20 gpm and refill rates up to 10 gpm.

The patent pending design features an "over-center" check disc to prevent prechecking during brine refill, when air in the brine line could cause excessive flow rates.

The 494 brine valve also features a new adjustable float design, which allows the float to be adjusted with a simple twist of the locking nut.

The 494 assembly (H4900) includes the brine valve, two brine connection elbows, adjustable float, air check assembly with 60" riser, 1" riser adapter and float rod guide.

## PRODUCT FEATURES

- High flow rates in both refill and draw position
- Plastic valve and air check
- Brine Valve molded from composite plastics to ensure strength and durability
- Easily adjustable float design with locking nut
- Easy access to check disk for serviceability
- Two Brine elbows included (1" PVC male and 3/4" x 1" PVC solvent)

## ORDER INFORMATION

Order No.	Description	Qty/Ctn
H4900	494 1" BRINE VALVE, FLOAT ASSEMBLY, AIR CHECK AND 60" RISER (AS SHOWN IN PICTURE)	1
H4940	494 1" BRINE VALVE AND FLOAT ASSEMBLY ONLY (LESS RISER AND AIR CHECK)	1
H4950	494 1" AIR CHECK (LESS RISER)	1
H4950-48	494 1" AIR CHECK WITH RISER (48" LENGTH)	6
H4950-60	494 1" AIR CHECK WITH RISER (60" LENGTH)	6

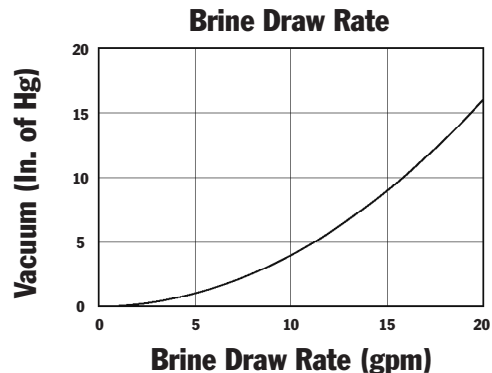
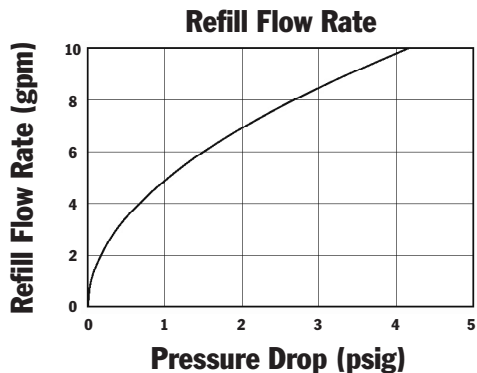



## 494 1" Commercial Brine Valve Installation Guide

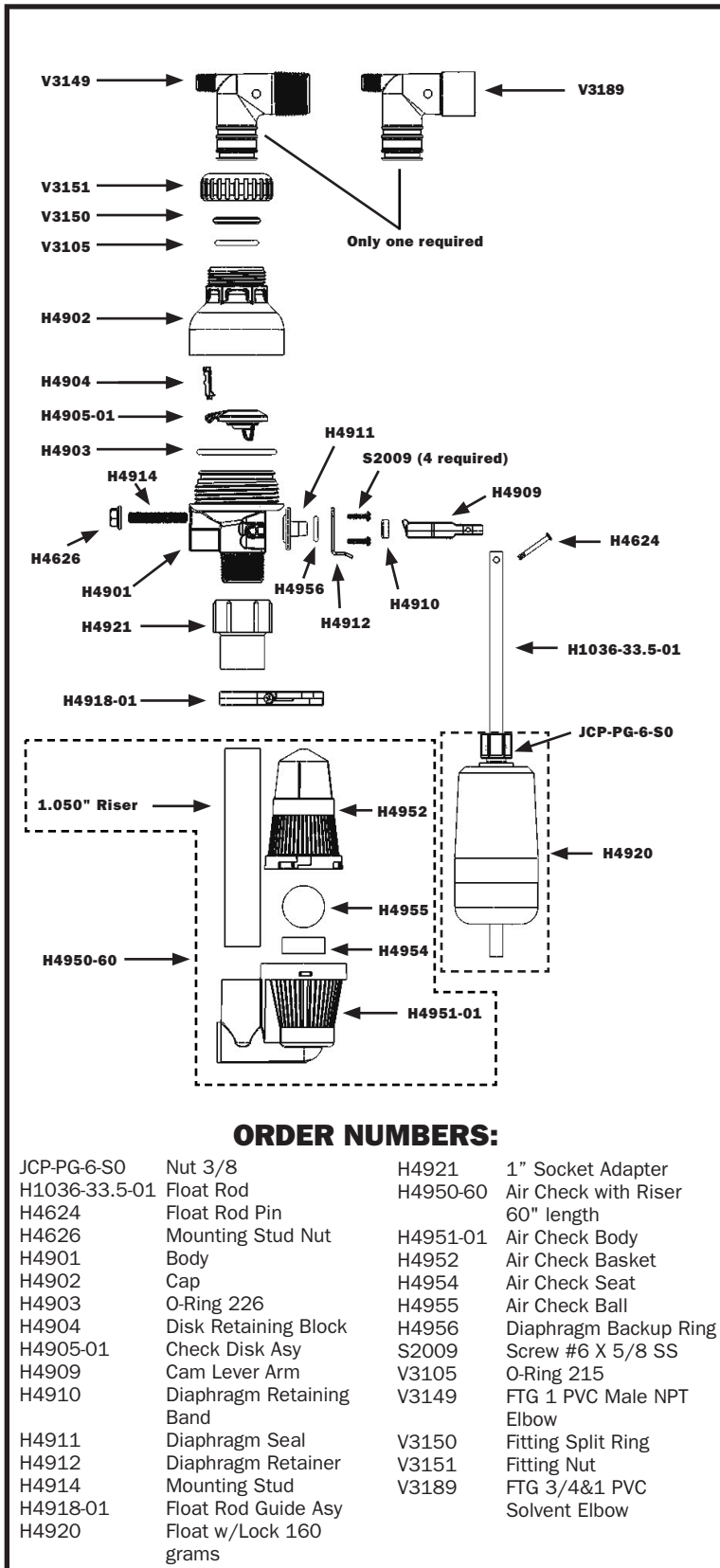

1. If an external flow control is used, install on the inlet side of the brine valve.
2. Use Teflon tape only on threaded plastic connections. Many liquid or paste pipe sealing products contain compounds that may cause plastics to crack with time.
3. Position float. Hand tighten the nut.
4. Place the float rod guide close to the float (but not as to hinder float operation), adjust the guide to position the float so float rod pin operates freely and tighten securely.
5. Position the assembly securely in the brine well and check to see that there is no interference with the float operation.

**NOTE:** When brine valve is used as a safety float for timed brine systems use refill rates up to 10 gpm. If used as a primary shut off, use refill rates up to 5 gpm. Repeated float closures at high refill rates can cause "water hammer," which may damage the plumbing. This brine valve is designed for salt brine only and will fit inside a brine well that is 5" diameter or larger.

---

---

## 7.3 Commercial/Industrial Rotationally Molded Brine Tanks

Commercial and industrial water softeners require a large volume of brine during each regeneration. From a capacity of 95 gallons to 500 gallons, our Rotationally Molded Brine Tanks are built to last. Molded out of durable, chemically resistant high density polyethylene, their 1/4" seamless walls won't bulge. All tanks and covers are black. Rotationally Molded Brine Tanks are strong enough to handle your toughest brine requirements.

Also available:

24" Plastic Grids

30" Plastic Grids

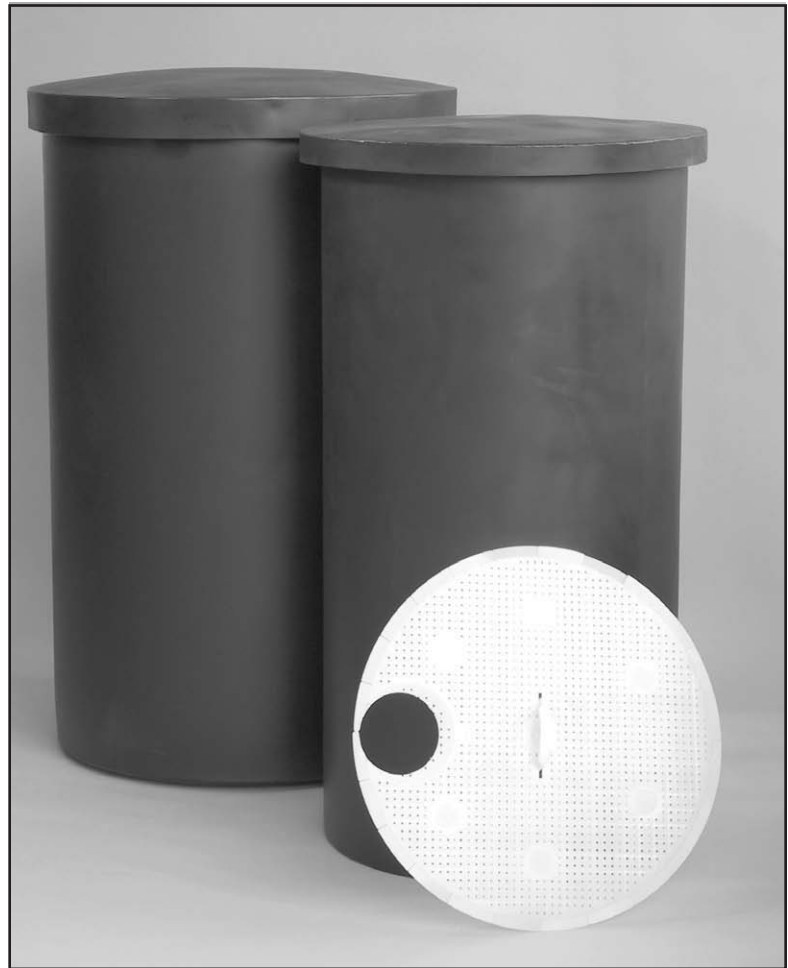

TANK SIZE	ORDER NUMBER	DIAMETER	HEIGHT	SALT CAPACITY	VOLUME	WEIGHT
24 x 48	G22448CB1P00	24"	48"	800 lbs.	95 gal.	30 lbs.
24 x 60	G22460CB1P00	24"	60"	1000 lbs.	115 gal.	32 lbs.
30 x 48	G23048CB1P00	30"	48"	1200 lbs.	145 gal.	48 lbs.
30 x 60	G23060CB1P00	30"	60"	1600 lbs.	180 gal.	56 lbs.
39 x 48	G23948CB1P00	39"	48"	2200 lbs.	250 gal.	67 lbs.
39 x 60	G23960CB1P00	39"	60"	2700 lbs.	300 gal.	80 lbs.
42 x 60	G24260CB1P00	42"	60"	3100 lbs.	350 gal.	84 lbs.
50 x 60	G25060CB1P00	50"	60"	4500 lbs.	500 gal.	107 lbs.

---

---

---

---

# **Section 8: 3900 Control Manual**

---

---

---

---

